

Town of Nags Head Residential Design Manual

for new construction and remodeling



Prepared for:
The Town of Nags Head
PO Box 99
Nags Head, North Carolina
(252) 441-7016

Prepared by:
Cahoon & Kasten Architects
118-A West Woodhill Drive
Nags Head, North Carolina
(252) 441-0271

Dated: _____



**Town of Nags Head Residential Design Manual
Table of Contents**

Terminologyi

Introduction.....1

Design Elements2

 Porches.....3

 Dormers.....5

 Coastal Watch Towers.....7

 Building Form9

 Roofs11

 Siding Materials13

 Miscellaneous Details15

Appendix A Residential Architectural Design Standards.....17

 Point Tabulation Form Instructions.....17

Appendix B19

 Point Calculation – Porch Example19

 Second Floor Plan – Example.....20

 Point Calculation – Elevations21

 Elevations.....22

Terminology

- Base Flood Elevation (BFE)** The height or elevation of the base flood as determined by FEMA. This is expressed in feet and represents the distance above sea level.
- Base Form** Shape of the building exterior wall perimeter in plan view. This does not include porches. See example below for outline of base form.

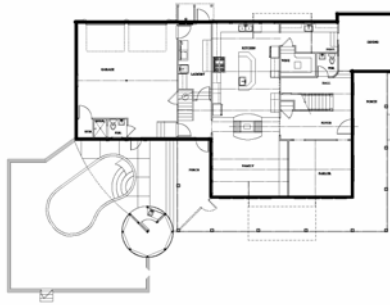

- Beauty Band** Horizontal trim details which break up large areas of siding usually aligned with floor level.
- Board and Batten** A siding detail which consists of narrow vertical siding trim (i.e. 1/4"x 1 1/2") spaced eight to twelve inches (8"-12") apart over flat siding. Historically this detail was made up of wide boards attached vertically to the building with narrow boards covering the joints.
- Bump-out** A break in the façade of the building which extends perpendicular from the exterior wall having its own independent roof structure or creating a variation of the main roof structure.
- Dormer** Walls with a window(s) placed vertically in a sloping roof with its own independent roof structure.
- Façade** The face or exterior form of a building.
- Fascia** A plain horizontal band sometimes placed at the termination of a roof at the edge of a building.*
- Finish Grade** Final level of the ground at the base of a building.
- First Floor** The first habitable floor four feet (4') or greater above the BFE or grade, which ever is higher. See diagrams below.
- Gable** The triangular upper portion of a wall at the end of a pitched roof.*
- Ground Floor** A habitable floor which is less than four feet (4') above BFE. See First Floor.
- Heated Living Area** The area (in plan view) of a building which is mechanically heated and/or cooled.

Hip	The external angle formed at the intersection of two sloping roof surfaces.*
Picket	Vertical member connecting the top and bottom of a railing.
Plan Area	The area of a horizontal building section.
Porch	Areas that are open and unobstructed (except for guard railings) to the exterior and are covered by a pitched roof that is supported by columns.
Proportion	Relation of things or parts of a thing.** In architecture, it is the relationship of building elements.
Rectilinear	Form or shape made up of right or 90 degree angles.
Ridge	A horizontal, longitudinal timber at the apex of a roof supporting the ends of the roof.*
Roof	Upper covering of a building.**
Scale	Size relationship of building parts to the whole building and the building to the environment.
Second Floor	A habitable floor level above the First Floor. See First Floor.
Shed	A single sloping roof form.
Siding	Outermost covering or material applied to the exterior walls of a building.
Top Plate	The top horizontal framing member of a building wall.
Watch Tower	A vertical projection above the sloped main roof of a building with windows around all sides.

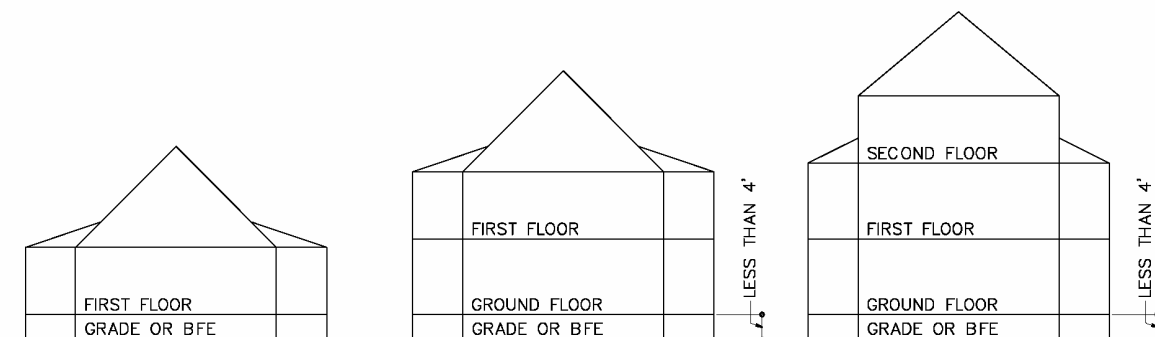

* The Penguin Dictionary of Architecture, John Fleming, Hugh Honour, Nikolaus Pevsner, Penguin Books 1991.

** The American Century Dictionary, Warner Books 1997.

Introduction

The Town of Nags Head has initiated a series of policies and regulations to protect and promote the unique and historical elements of residential architecture held to be valued as an integral part of the Town image (Town Code Section 22-267 Residential Design Standards). One component of these regulations is a series of Architectural Design Standards that are applicable to certain categories of Residential Structures within the Town.

The goal of these design standards is to produce architecture with a "Nags Head style" or "coastal style" without stifling creative design or causing a monotonous built environment. A point system will be used to encourage the desired design for certain categories of residential structures. Applicants, at their discretion, will choose from a menu of design elements to achieve unique designs that are reflective of the aforementioned design styles. The "Nags Head style" is architectural design reminiscent of the existing houses on the oceanfront near Jockey's Ridge (see illustration 1) and the "Coastal style" is architectural design reminiscent of the historic Life Saving Service buildings of eastern North Carolina (see illustration 2).



1. Nixon Residence, Nags Head, NC



2. 1903 Kinnakeet Life Saving Station, Avon, NC

The most desirable design element of these styles is the wraparound porch which shall have the greatest value in the point system. Other elements include dormers, coastal watch towers, pitched roofs, siding materials, and other miscellaneous details such as exposed rafter tails, working shutters, and porch column trim.

This manual has been created to assist property owners and residential developers with these design standards to ensure that the development application process is as efficient as possible. In this manual you will find a description of the design features or "design elements" that are being encouraged throughout the Town. Also included is a description of the point system that is being used to evaluate each building design. Finally, examples have been incorporated to illustrate how individual design elements are assigned points and how combinations of design elements can be used to achieve the desired point totals for each category of residential structure.

Our community can be enhanced by the improvement of the built environment. By using a palette of architectural details blended together in a cohesive design, we can create a pleasing built landscape that will complement the beautiful area in which we live.

Design Elements

Design elements give architecture a particular style or appeal. A number of design elements have been identified that contribute to the "Nags Head" and "Coastal" architectural styles. Many of these were mentioned in the Introduction. If these design elements are incorporated in proper proportion, we can create the desired architectural style.

The written and illustrated design criteria contained on the following pages has been specified for each design element to create the appearance of the original architecture. This is important because these elements, if not sized properly, can appear applied to the "skin" of the house making the architecture look contrived or forced. The elements need to look functional. A simple rule of thumb although not a standard to evaluate the design, is to determine if the element is useable. For example, operable shutters inherently have a more desirable look than shutters permanently attached to the side of a window with no working hardware.

Combinations of these design elements, at the discretion of the applicant, shall be included in any new residential construction or remodeling project that meets one of the following criteria:

- New residential construction five bedrooms or greater (except within the Village at Nags Head).
- Remodel of an existing residential structure where the number of bedrooms is being increased to five (5) bedrooms or greater and the value of the project exceeds one hundred percent (100%) of the current assessed tax value of the structure.
- Remodel of an existing residential structure that is five (5) bedrooms or greater where the value of the project exceeds one hundred percent (100%) of the current assessed tax value of the structure.

The size of the house, based on the number of bedrooms, will determine the total number of points that must be achieved. The minimum number of required points is determined by multiplying the number of bedrooms by twelve (12). Homes greater than eight bedrooms are not permitted. In addition to the design criteria specified for each design element, the following pages include a discussion of the point values assigned to each design element and how these can be determined.

Porches

Porches, while being a standard architectural feature on “Nags Head Style” homes, can soften the harshness of a plain rectilinear form and create an appealing transition from inside to outside. Historically, the function of porches in this environment was to shade windows from direct sun and create a place in the shade to take advantage of breezes. The porches also offered protection of windows and doors in the event of storms.

All rectilinear areas that are open and unobstructed (except for guard railings) to the exterior, covered by a pitched roof which is supported by columns, shall be considered a porch. Porches shall also have the following characteristics: (see illustration 3)

1. Porch Depth - A minimum porch depth of six feet (6') is just enough to give the appearance of a working porch. However, it may be a little narrow for use with chairs. Eight feet (8') is the minimum for comfortable placement of chairs. Porches become disproportionately deep after 10'. Porch depth is calculated from the exterior wall of the structure to the exterior edge of the porch column.
2. Roof Pitch – For the porch roof pitch to have the desired look, a minimum of 3/12 pitch should be used. Historically, porch roof pitches were steep to shed rain water, which is still an important consideration today.
3. Guard Railing – The use of a top and bottom rail is desirable and more historic than the now dated look of pickets overlapping the deck band. Intermediate horizontal rail enclosures can be used as well as vertical pickets and is probably a more desired look. However, this does create the potential for use as a ladder by small children.
4. Porch plans shall be square or rectangular in plan.
5. First Floor – The First Floor shall be the first habitable floor four feet (4') or greater above the BFE or grade, whichever is higher. A habitable floor level less than four feet (4') above BFE shall be considered a Ground Floor. In structures having three (3) floor levels, the first level shall be considered the Ground Floor, the second floor level, the First Floor and the third level, the Second Floor. See Terminology for diagram.

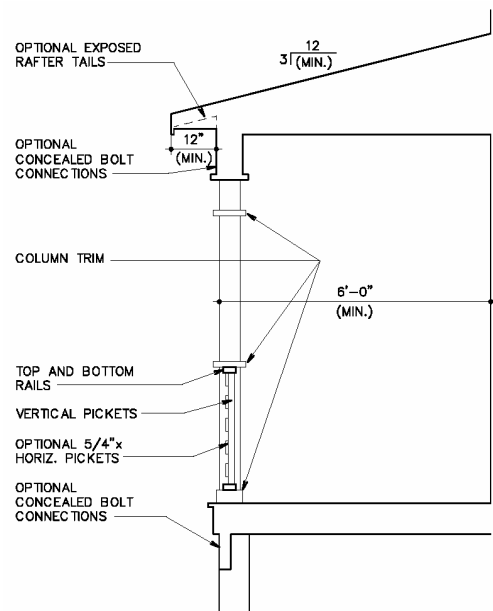

Illustration 3

Scoring

First floor Porch

To calculate the number of possible points for a first floor porch, two measurements will be needed:

- 1) The perimeter of heated living area of the first floor (b1)
- 2) The perimeter of the portion of the first floor that has an adjacent porch meeting the required specifications (p1)

Divide the perimeter with the porch (p1) by the perimeter of the entire floor (b1). For first floor porches, multiply the result by 150 to calculate the total points.

$$(p1/b1)*150 = \text{points for first floor porch}$$

Second Floor Porch

To calculate the number of possible points for a second floor porch, two measurements will be needed:

- 1) The perimeter of heated living area of the second floor (b2)
- 2) The perimeter of the portion of the second floor that has an adjacent porch meeting the required specifications (p2)

Divide the perimeter with the porch (p2) by the perimeter of the entire floor (b2). For second floor porches, multiply the result by 75 to calculate the total points.

$$(p2/b2)*75 = \text{points for second floor porch}$$

A diagram illustrating this calculation is included in Appendix B.

Porch



Wrap-around Porch



Dormers

Dormers are constructed in a roof to provide light and ventilation into habitable or attic space. Dormers can also create head room thus making a useable space out of the roof structure. From an architectural point of view, dormers break up the monotony of a large roof and, if the roof structure becomes habitable, make the structure seem shorter and smaller. A window placed vertically in a roof having a hip, gable, or shed roof can be considered a dormer (see illustrations 4 & 5).

1. Hip and Gable Dormers – A minimum width of 5', height of 4' (from roof to top plate of dormer at front) and a pitch of 6/12 will give the desired appearance. If the dormer is too small it starts to appear out of character with the desired architectural style. The roof for this size of dormer should be hipped or gabled.
2. Shed Dormer – A minimum width of 12', height of 4' (from roof to top plate of dormer at front) and a pitch of 3/12 will give the desired appearance. If the dormer is made too small it starts to appear out of character with the desired architectural style. The roof for this size of dormer should be a shed.
3. A dormer should be square or rectangular in plan.

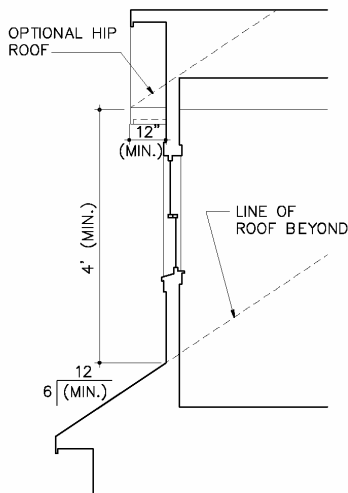

Illustration 4

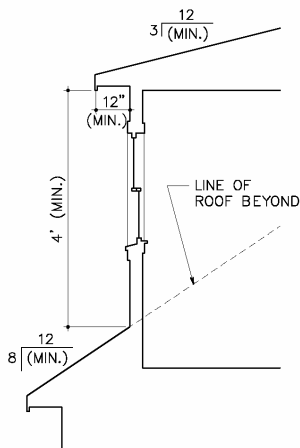
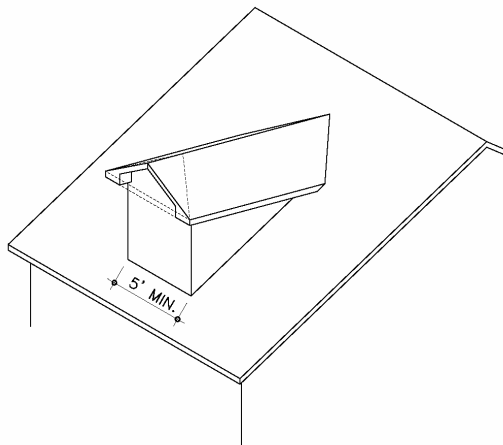
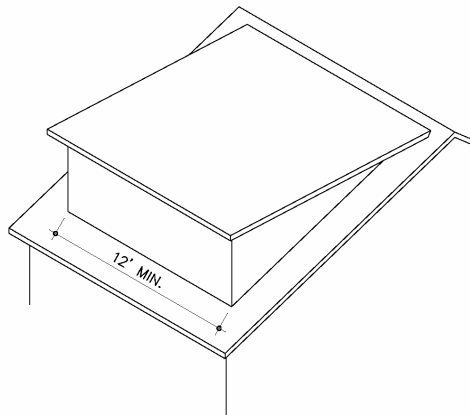

Illustration 5



Scoring

To calculate the points for hip or gable dormers, multiply the total number (n) of dormers meeting the required specifications by five (5).

$$n \times 5 = \text{points for hip or gable dormers}$$

To calculate the points for shed dormers, multiply the total number (n) of dormers by ten (10). If the length (L) of the shed dormer is greater than twelve feet, additional points will be awarded. Add only the number of feet greater than twelve to the score. For instance, if the dormer is 16 feet in length, four (4) feet will be added to the score.

$$n(10) + L = \text{points for shed dormers}$$

A maximum of 25 points will be awarded for dormers.



Hip Dormers



Gable Dormers



Shed Dormer

Coastal Watch Towers

Historically, coastal watch towers provided a view up and down the beach for the men of the Life Saving Service. They had windows around all sides and projected above the ridge of the main roof to achieve their intended function.

A vertical projection above the sloped main roof with the following characteristics shall achieve the desired architectural style: (see illustration 6)

1. A tower that is at least six feet (6') wide and no more than fourteen feet (14') wide and at least 60 square feet and not more that 196 square feet is within the size of the original "coastal watch towers".
2. The tower should maintain windows on all sides to have the impression of offering a 360 degree view of the land.
3. The roof should be at least a 6/12 pitch to match the design intent.
4. These structures should be square or rectangular in plan.

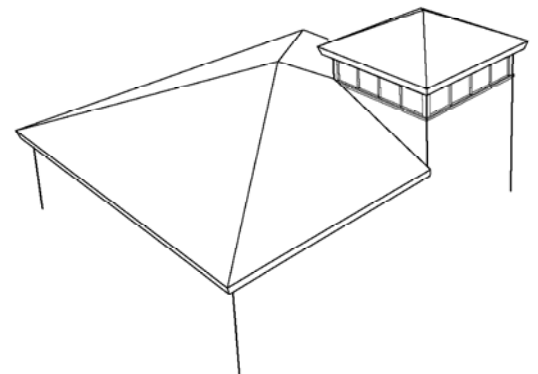
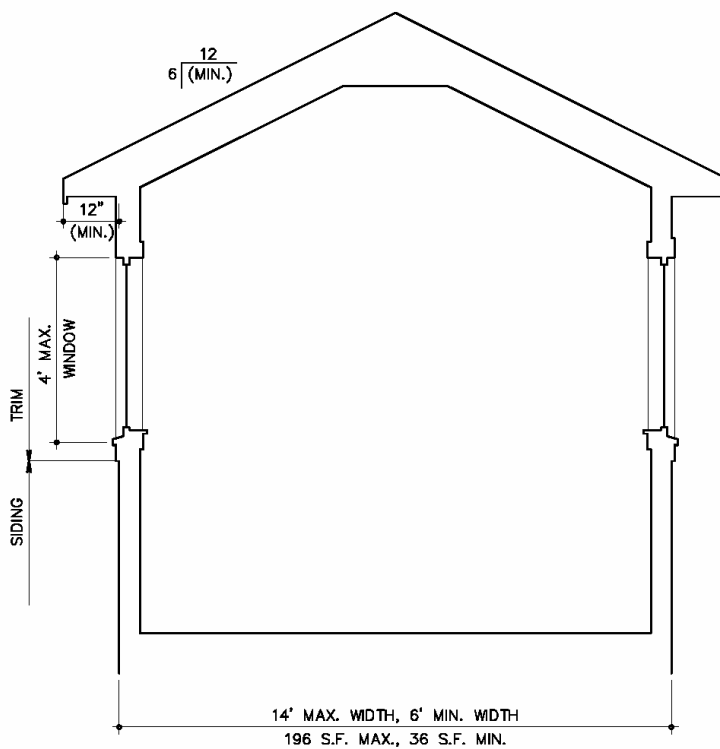

Illustration 6

Scoring

Coastal Watch Towers meeting the above specifications will be awarded ten (10) points.



Coastal Watch Tower

Building Form

The proper building form is essential to create the desired architectural style. With the addition of a “wrap-around” porch to a simple rectilinear form, we can achieve the “Nags Head style”. However, there are many structures with base forms that give variety to an otherwise plain shape.

In the heated area of a building, the following characteristics are desired:

1. Bump-outs – A break in the façade of the building which extends at least two feet (2') perpendicular from the exterior wall and is at least 25% of the façade area, either as one element or several, shall be considered a bump-out (see illustrations 7 and 8). A bump out should have its own independent roof structure or should result in a variation of the main roof structure.
2. Combination Base Forms – A building having a combination of base forms was historically the result of some sort of addition. This addition was usually large enough to include one or more rooms. For a structure to meet this type of form, it should have at least two base forms one being as least 25% of the size of the main or largest forms. The base forms should be considered the plan area of heated space. (see illustration 9)
3. The baseform of the building shall be square or rectangular in plan.

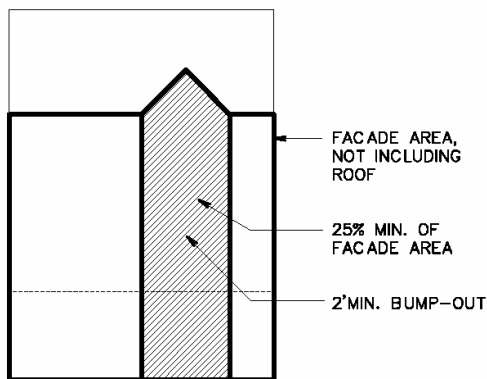

Illustration 7

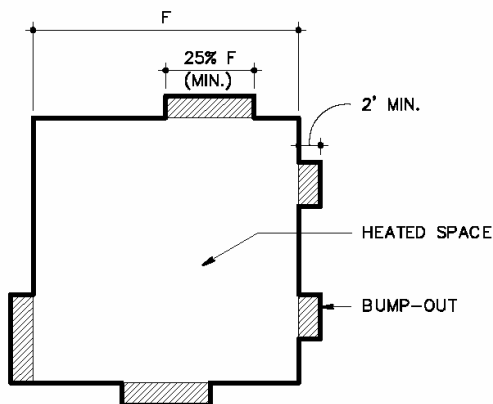

Illustration 8

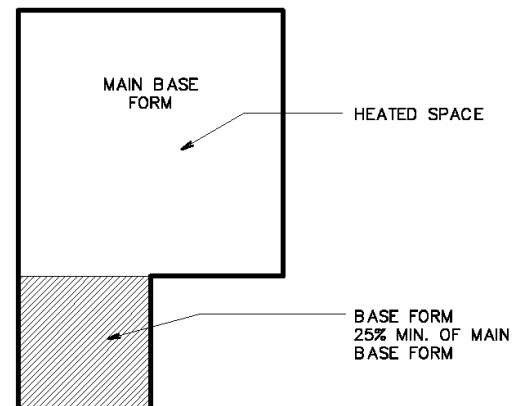

Illustration 9

Scoring

1. Bump outs meeting the required specifications will be awarded ten points per side or façade (f).

F = façade with required bump out.

$F \times 10 =$ points for bump outs

2. A structure that is designed with a combination of base forms will be awarded 40 points.

The maximum score for the building form category is 40 points. Points will not be awarded for bump outs if a structure is already receiving the maximum points for a combination base form.

A diagram illustrating the calculation of points for building form is included in Appendix B.



Bump-outs



Combination Base Forms

Roofs

The roof of the house plays a tremendous role in establishing the form of the structure. With proper pitch and type, the roof can go a long way in achieving the desired form. The “Nags Head” and “Coastal” styles both use roofs that have a reasonable pitch to shed stormwater.

The roofs should have the following characteristics:

1. Main roof pitch – The main roof pitch should be a minimum of 8/12.
2. Main roof form – The main roof is that portion of the roof covering the largest habitable part of the structure. Gable, hip and intersecting gable or hip roofs which are rectilinear in plan are standard for the desired architectural style. Shed, gambrel, opposing sheds, or mansard roofs (on the main roof) evoke architectural styles that are not common historically to this area.
3. In order to avoid the contemporary “chalet” house look, the structure should have one full floor height below the main roof eave. Roofs that incorporate dormers would not apply to this requirement.

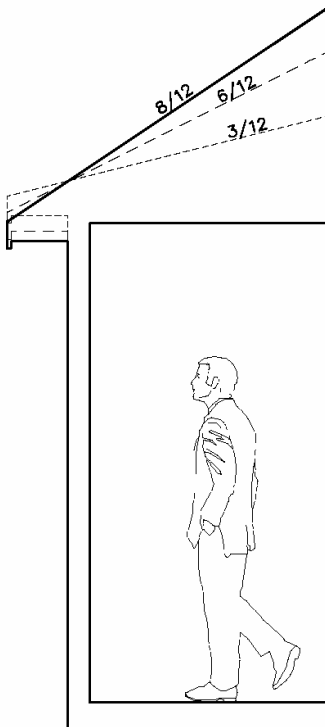

Roof Pitches

Scoring

A roof meeting the required specifications will be awarded 25 points.

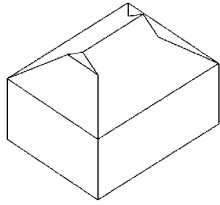

Dutch Hip Roof

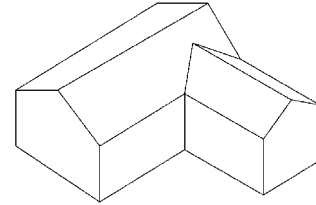

Intersecting Gable Roof

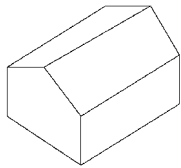

Gable Roof

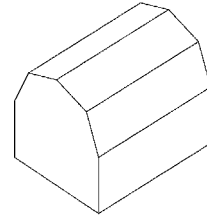

Gambrel Roof

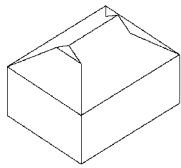

Hip Roof

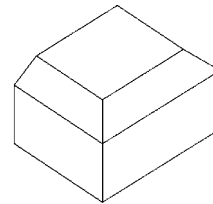

Mansard Roof

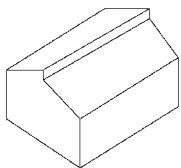

Opposing Shed Roof

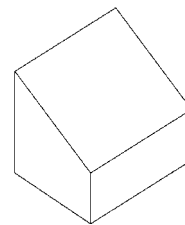

Shed Roof

Siding Materials

Historically, the most common siding material on the Outer Banks was the wood shingle. This is certainly a major element in "Nags Head" and "Coastal" style architecture. Most historic uses of this material involved allowing the shingles to weather to a natural gray; however, staining the material is an acceptable option.

Siding materials should be one of the following which must cover at least 80% of the siding area:

1. Wood shingles - Wood material should be red cedar, white cedar, juniper, or pressure treated pine.
2. Simulated wood shingles - Material may be any type which mimics the appearance of wood shingles or shakes including cementitious and vinyl products.

Scoring

A structure with wood shingle or shake siding meeting the required specifications will be awarded 25 points.

A structure with simulated wood shingle siding meeting the required specifications will be awarded 12 points.



Vinyl Shingle Siding



Wood Shingle Siding

Miscellaneous Details

These details should be applied throughout the design wherever possible and reasonable.

A building may include any of the following:

1. Working Shutters – Shutters should be designed and installed to protect the windows in the event of a storm. Both side and top hinged shutters are part of the desired architectural style; however, rolling shutters are not. The shutters should be a board and batten style.
2. Windows - 75% of the predominate window shape should be rectangular and be double or single hung.
3. Beauty Bands - Beauty bands are horizontal trim details which break up large areas of siding. This trim should be a minimum of 8" wide and be at floor level.
4. Exposed Rafter Tails - Exposed rafter tails are the portion of roof rafters beyond the plane of the exterior walls or porch columns supporting the roof at the eaves. The rafter tails should be seen or exposed to the exterior. They can be of pressure treated material or painted.
5. Porch Column Trim - This trim should at a minimum include some type of trim at the top of the column (capital trim) and at the bottom (base trim). Additional trim can be added at the railing height.
6. Gable Bracket - The gable bracket, at a minimum, consists of a horizontal and a vertical piece of trim aligned with the eave fascia at a gable roof. This trim should be placed at the center of the gable and mimic the traditional "Life Saving Station" detail.

Scoring

For features that meet the required specifications, the following points will be awarded:

1. Working Shutters – 15 points
2. Windows – 20 points
3. Beauty Bands – 5 points
4. Exposed Rafter Tails – 5 points
5. Porch Column Trim – 5 points
6. Gable Bracket – 5 points



Working Shutters (side hinge)



Beauty Bands



Working Shutters (top hinge)



Porch Column Trim



Exposed Rafters



Gable Bracket



Town of Nags Head

Appendix A Residential Architectural Design Standards

Point Tabulation Form Instructions

The Town of Nags Head has initiated a series of policies and regulations to protect and promote the unique and historical elements of residential architecture held to be valued as an integral part of the Town image (Town Code Section 22-267 Residential Design Standards). One component of these regulations is a series of Architectural Design Standards that are applicable to certain categories of Residential Structures. The Architectural Design Standards and the associated Architectural Point System are described in detail in the *Town of Nags Head Residential Design Manual*. Copies of this document can be obtained from the Planning and Development Department or can be downloaded from the Town website at (www.townofnagshead.net).

If your project consists of one of the following elements, a completed Residential Design Point Tabulation Form (see attached) is required with your Development Permit Application Form:

- New residential construction five bedrooms or greater (except within the Village at Nags Head).
- Remodel of an existing residential structure where the number of bedrooms is being increased to five (5) or greater and the value of the project exceeds one hundred percent (100%) of the current assessed tax value of the structure.
- Remodel of an existing residential structure that is five (5) bedrooms or greater where the value of the project exceeds one hundred percent (100%) of the current assessed tax value of the structure.

In addition to this completed form, please identify on the building plans in sufficient detail (elevations and floor plans) the elements that have been incorporated to satisfy the point requirements of the Architectural Design Standards. An example of a completed Residential Design Point Tabulation Form is included in Appendix B of the *Town of Nags Head Residential Design Manual*.

This information will be reviewed by Town Planning and Development Staff as part of the Development Permit Application Process. For questions or information regarding these policies and procedures, please contact the Planning and Development Department at 252-441-7016.

Town of Nags Head Residential Design Manual – Point Tabulation Form

The architectural design elements listed in the table below have been assigned individual point values. At the discretion of the Applicant, a combination of these elements must be incorporated into the design of each dwelling in order to achieve the minimum required point totals. The architectural standards apply only to homes with five (5) bedrooms or greater. To calculate the required points, multiply the number of bedrooms by twelve (12). Please reference the *Town of Nags Head Residential Design Manual* for a description of each design element and their required specifications. This document can be obtained from the Planning and Development Department (252-441-7016) or can be downloaded at the Town website (www.townofnagshead.net).

DESIGN ELEMENT*	FORMULA/NO. OF POINTS POSSIBLE	POINTS
Porches	<p>First Floor Porches – $p1/b1 \times 150 =$ $p1 = \text{perimeter of first floor with porch}$ $b1 = \text{perimeter of first floor}$</p> <p>Second Floor Porches – $p2/b2 \times 75 =$ $p2 = \text{perimeter of second floor with porch}$ $b2 = \text{perimeter of second floor}$</p>	
Dormers (25 points max.)	<p>Hip or Gable – $n \times 5 =$ Shed – $n(10) + L =$ $n = \text{no. of dormers}$ $L = \text{linear ft. past 12'}$</p>	
Coastal Watch Tower (10 points max.)	10	
Roofs	25	
Building Form (40 points max.)	<p>Bump Outs – $f \times 10 =$ $f = \text{façade with required bump outs}$</p> <p>Combination Base Form = 40</p>	
Siding Materials	<p>Wood Shingles = 25 Simulated Wood Shingles = 12</p>	
Misc. Details	<p>Windows = 20 Workable Shutters = 15 Exposed Rafter Tails = 5 Beauty Bands = 5 Column Trim = 5 Gable Bracket = 5</p>	
Minimum Required Point Total for Dwelling Category Two (2) and Dwelling Category Three (3)		12 X Number of Bedrooms

*Meeting the specifications as indicated in the Town of Nags Head Residential Design Manual

Appendix B

Point Calculation – Porch Example

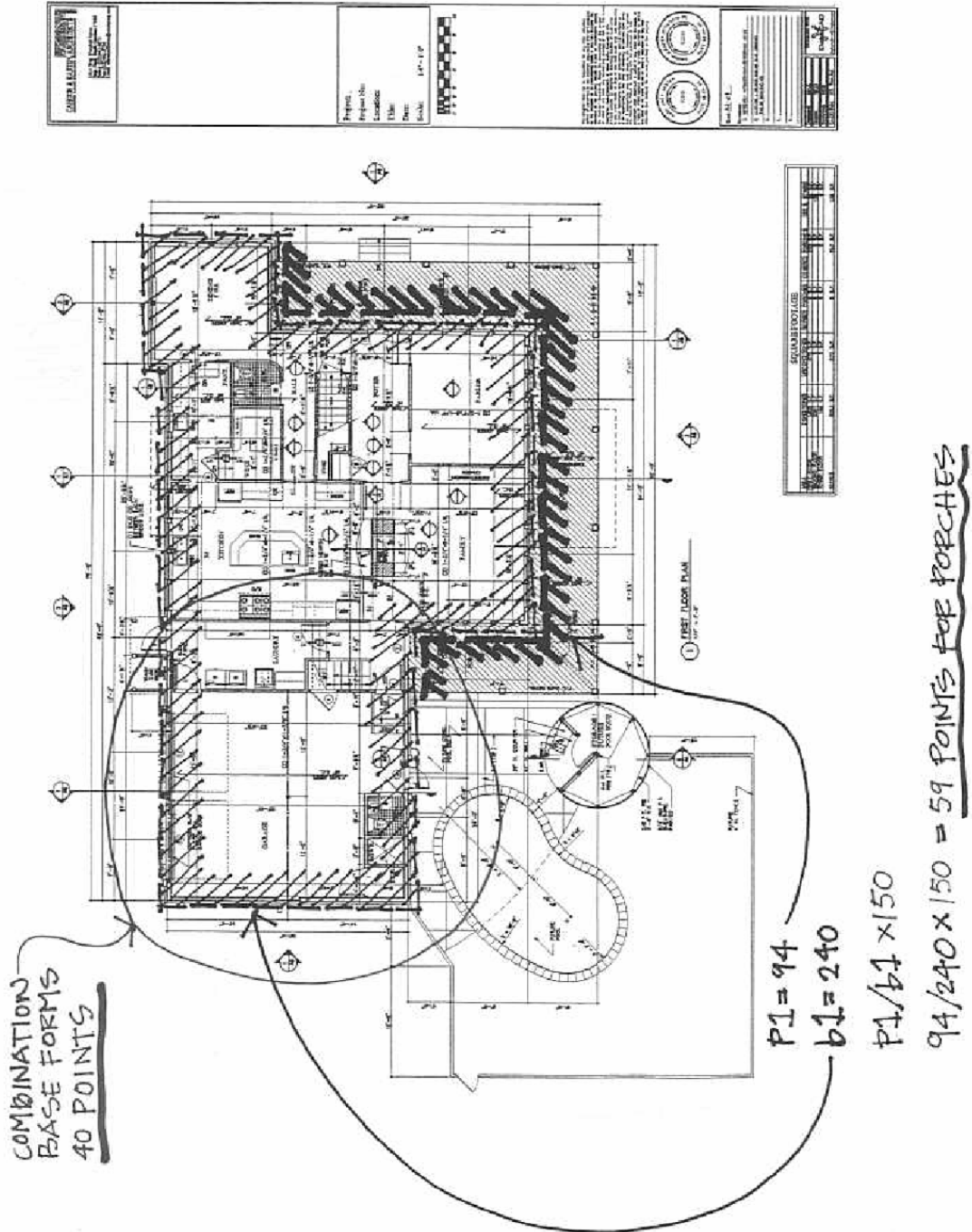

Second Floor Plan – Example

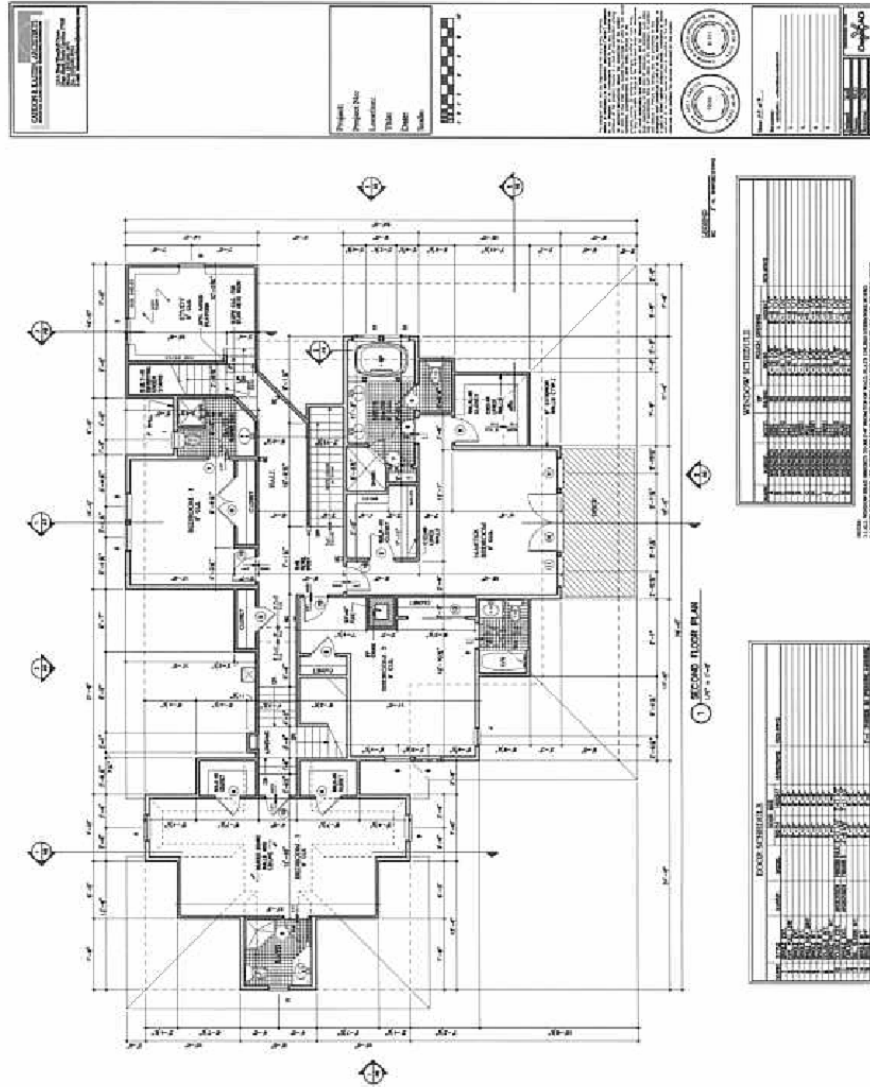

Point Calculation – Elevations

ROOF
8/12 PITCH
25 POINTS

DORMER TOO SHORT,
0 POINTS

DOUBLE HUNG WINDOWS
20 POINTS

COLUMN TRIM
5 POINTS

WOOD SHINGLES
25 POINTS

SHUTTERS
15 POINTS

BEAUTY BAND
5 POINTS

TOWER
10 POINTS

6 DORMERS
11 X 5
6 X 5 = 30 POINTS
25 POINTS MAX.

FRONT ELEVATION
1/4" = 1'-0"

RIGHT ELEVATION
1/4" = 1'-0"

Project No.	
Location	
Title	
Date	10-1-10
Scale	

Elevations

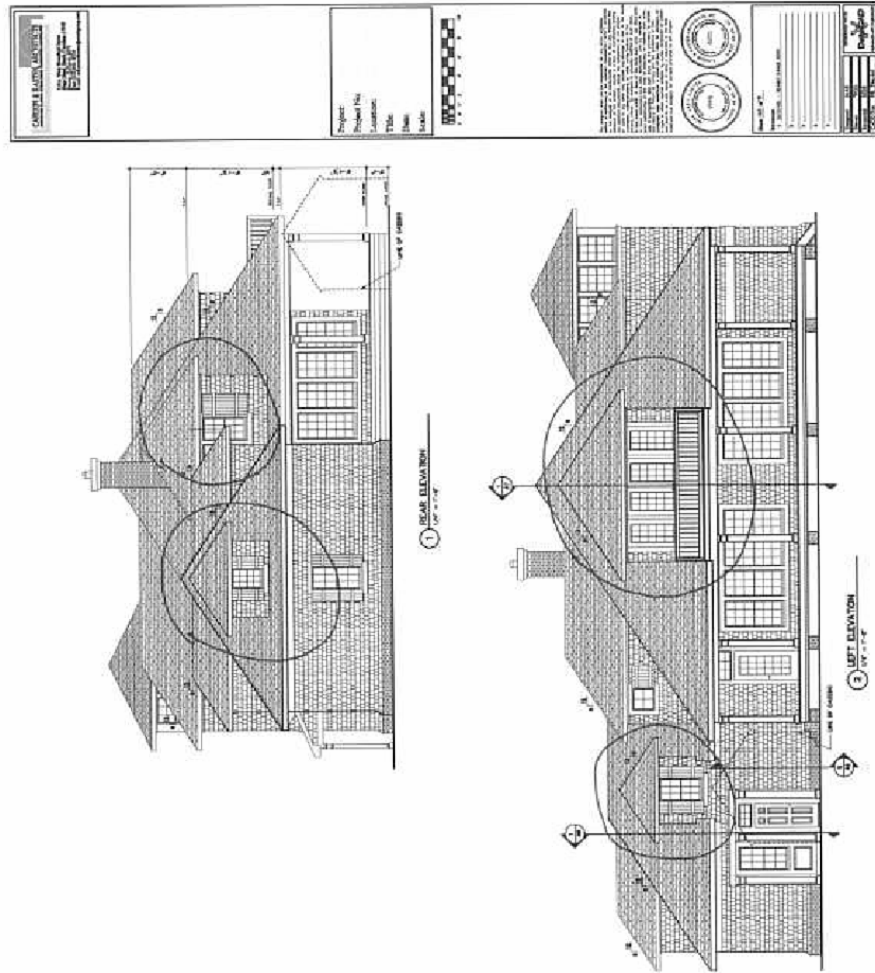

Nags Head Residential Design Manual
Residential Design Manual – Point Tabulation Form

Project: Example

Location:

DESIGN ELEMENT*	FORMULA/NO. OF POINTS POSSIBLE	POINTS
Porches	<p><i>First Floor Porches – $p1/b1 \times 150 =$</i> <i>$p1 =$ perimeter of first floor with porch</i> <i>$b1 =$ perimeter of first floor</i></p> <p><i>Second Floor Porches – $p2/b2 \times 75 =$</i> <i>$p2 =$ perimeter of second floor with porch</i> <i>$b2 =$ perimeter of second floor</i></p>	<p>59</p> <p>0</p>
Dormers (25 points max.)	<p><i>Hip or Gable – $n \times 5 =$</i> <i>Shed – $n(10) + L =$</i> <i>$n =$ no. of dormers</i> <i>$L =$ linear ft. past 12'</i></p>	25
Coastal Watch Tower (10 points max.)	10	10
Roofs	25	25
Building Form (40 points max.)	<p><i>Bump Outs – $f \times 10 =$</i> <i>$f =$ façade with required bump outs</i></p> <p><i>Combination Base Form = 40</i></p>	<p>0</p> <p>40</p>
Siding Materials	<p><i>Wood Shingles = 25</i></p> <p><i>Simulated Wood Shingles = 12</i></p>	25
Misc. Details	<p><i>Windows = 20</i></p> <p><i>Workable Shutters = 15</i></p> <p><i>Exposed Rafter Tails = 5</i></p> <p><i>Beauty Bands = 5</i></p> <p><i>Column Trim = 5</i></p> <p><i>Gable Bracket = 5</i></p>	<p>20</p> <p>15</p> <p>0</p> <p>5</p> <p>5</p> <p>0</p>
Total Points		229